

Waterco high performance pumps



Hydrostorm, Hydrostorm Plus, Hydrostar



Designed for commercial and extra large domestic pools, Waterco high performance pumps provide the extra power needed to cope with ancillary systems like water features, infloor cleaning, vacuum cleaning and swim/spa jets.



Hydrostorm



Hydrostorm Plus



Hydrostar



Efficient Impeller and Diffuser Design

The pump's impeller and diffuser design maximizes the hydraulic output of the pump while minimizing turbulence. The pump's efficient hydraulic performance shortens run times and reduces energy consumption leading to lower operating costs.

Engineered Durability

The pump body is manufactured utilising state of the art engineering plastic moulding with a single piece strainer pot and volute for extra strength.

A high grade 316 stainless steel mechanical seal is incorporated for extra protection against corrosion. e.g. from chlorinated water, ozone, iodine, Baquacil, bromine and salt water.

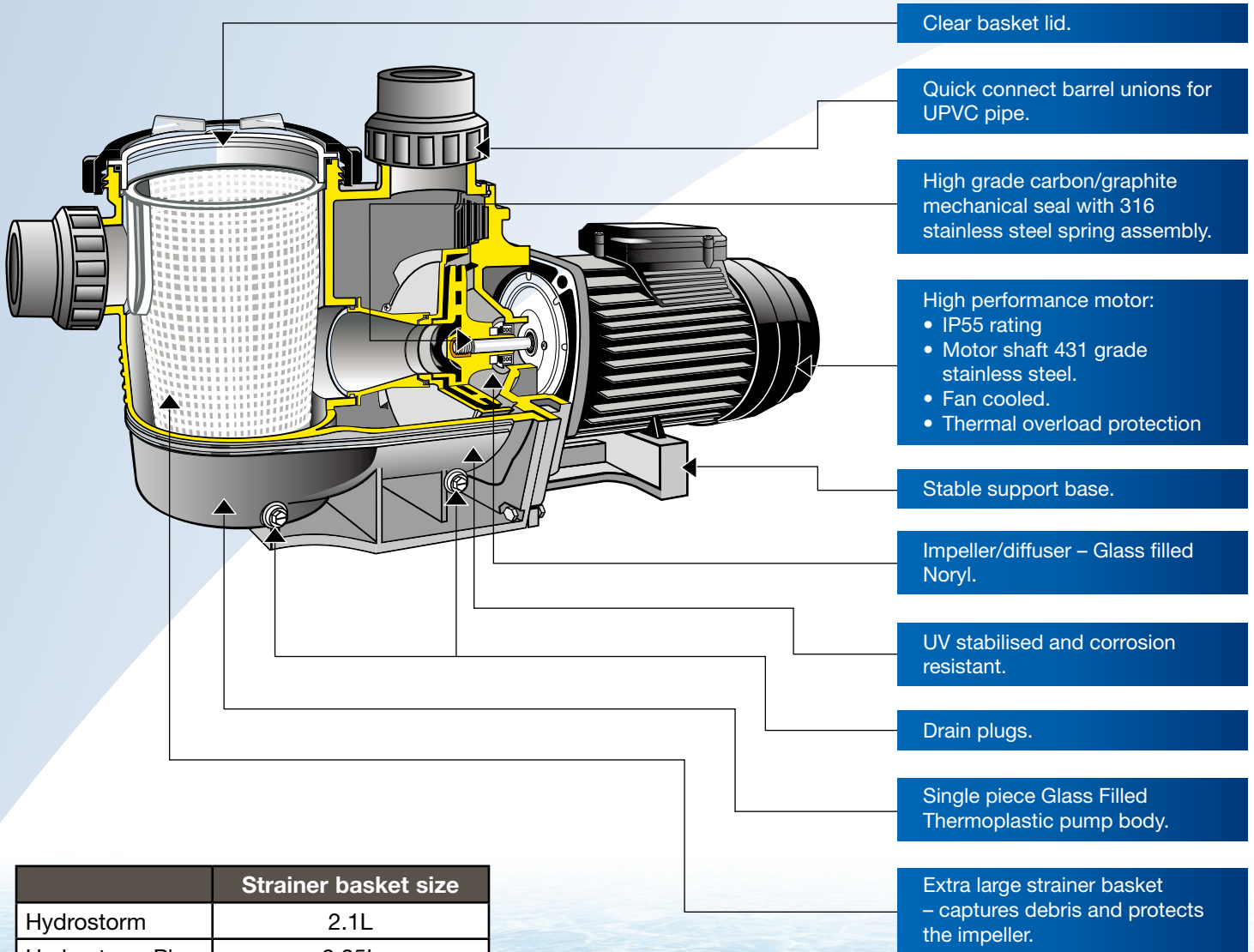

	Strainer basket size
Hydrostorm	2.1L
Hydrostorm Plus	2.25L
Hydrostar	6L

Hydrostorm

The Hydrostorm is designed to have all the extra power you need to cope with modern day swimming pool designs.



Flow Curves

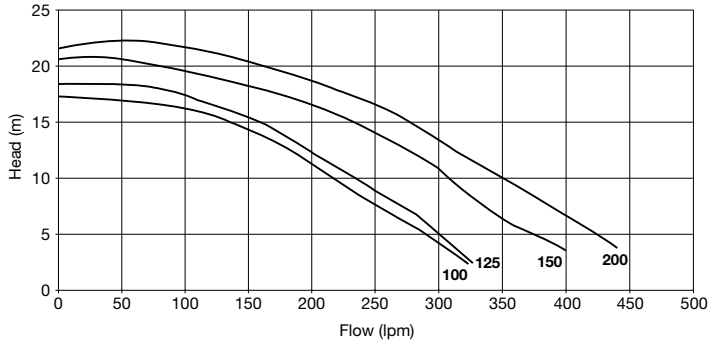

Sound Levels

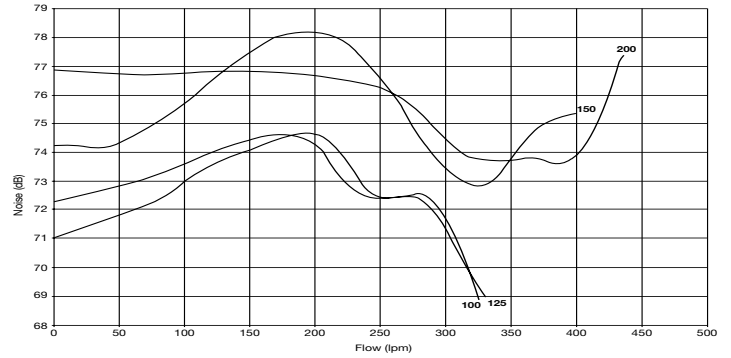

Technical specification

Model	Flow rate (lpm)		Nom. HP	kW	Amps	Phase	Total Length (mm)	Motor Frame (mm)	Inlet/Outlet
	8m	10m							
Hydrostorm 100	248	219	1	0.91	4.00	1	600	71	50mm ports x / 50mm unions
Hydrostorm 125	267	237	1.25	1.08	4.80	1	600	71	50mm ports x / 50mm unions
Hydrostorm 150	336	309	1.5	1.31	5.80	1	647	80	50mm ports x / 50mm unions
Hydrostorm 200	379	350	2	1.46	6.60	1	647	80	50mm ports x / 50mm unions

Phase	Volts	Cycle	RPM
1	220- 240	50	2860

Dimension

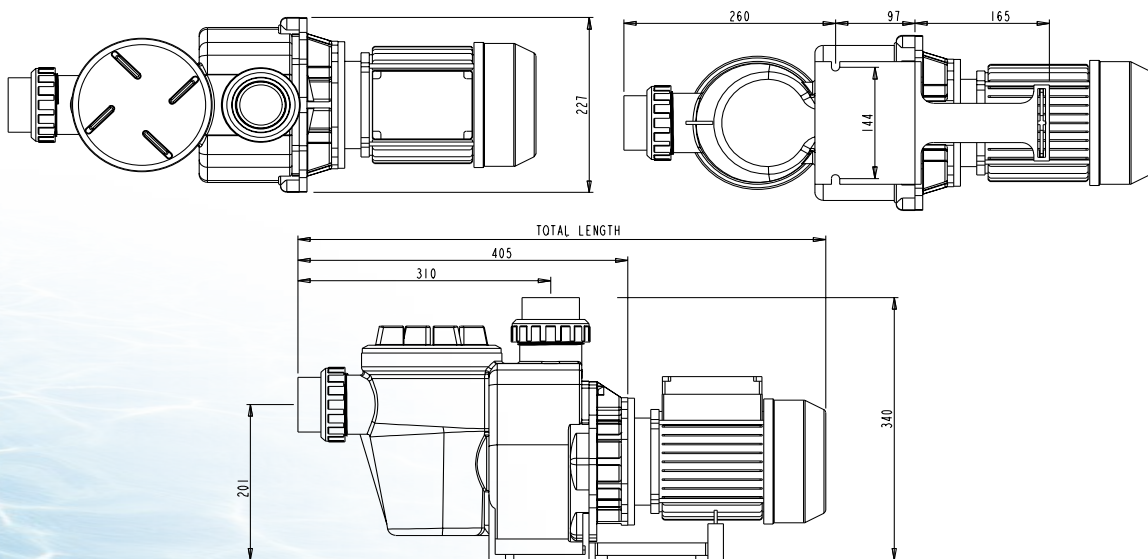

Hydrostorm Plus

The Hydrostorm plus has all the proven features of the Hydrostorm with the addition of an innovative lid & lock ring for easier maintenance and a larger strainer basket for increased capacity.



Flow Curves

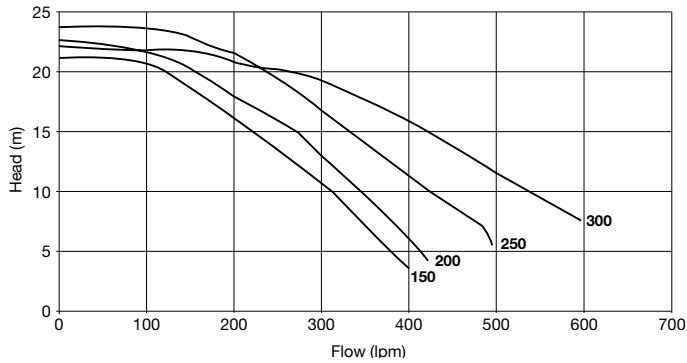

Sound Levels

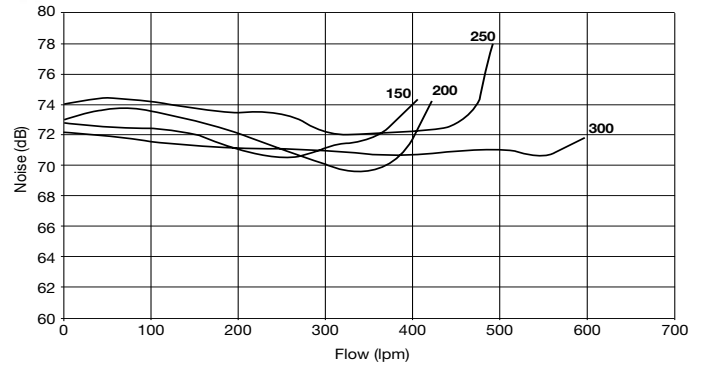

Technical specification

Model	Flow rate (lpm)		Nom. HP	kW	Amps	Phase	Total Length (mm)	Motor Frame (mm)	Inlet/Outlet
	8m	10m							
Hydrostorm Plus 150	336	309	1.5	1.40	5.8	1	678	80	50mm ports x / 50mm unions
Hydrostorm Plus 200	379	350	2	1.51	6.3	1	678	80	50mm ports x / 50mm unions
Hydrostorm Plus 250	479	449	2.5	1.85	7.8	1	678	80	65mm ports x / 50mm unions
Hydrostorm Plus 300	588	549	3	2.08	9.0	1	730	90	65mm ports x / 50mm unions

Phase	Volts	Cycle	RPM
1	220- 240	50	2860

Dimension

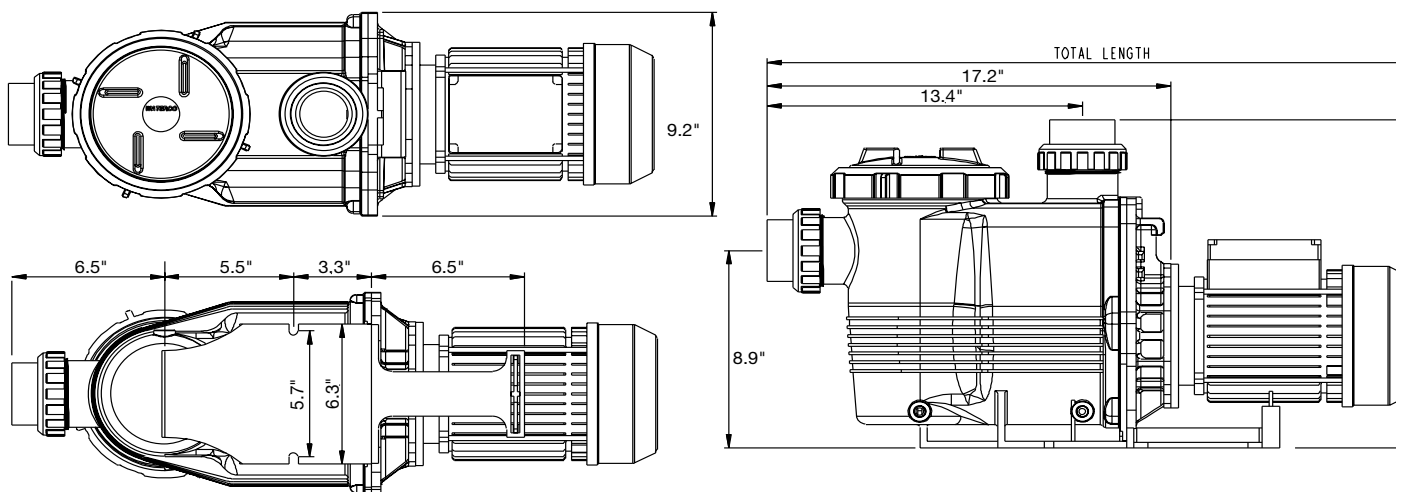

Hydrostar

Built with an innovative quarter lid & lock ring and extra large strainer basket, the Hydrostar is ideal for large domestic and commercial sized swimming pools.



Flow Curves

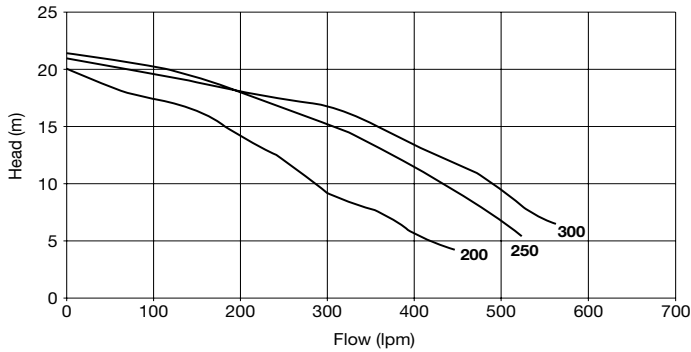

Sound Levels

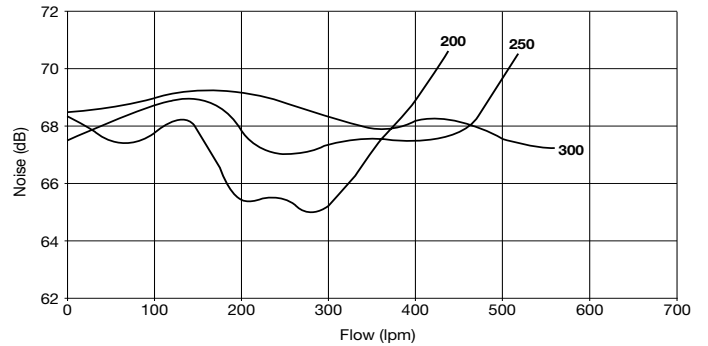

Technical specification

Model	Flow rate (lpm)		Nom. HP	kW	Amps	Phase	Total Length (mm)	Motor Frame (mm)	Inlet/Outlet
	8m	10m							
Hydrostar 200	340	286	2	1.46	6.5	1	771	80	65mm ports x / 50mm unions
Hydrostar 250	475	438	2.5	1.96	9.3	1	771	80	65mm ports x / 50mm unions
Hydrostar 300	524	488	3	2.33	10.9	1	792	90	65mm ports x / 50mm unions
Hydrostar 300	524	488	3	2.33	10.9	1	792	90	80mm ports x / 80mm unions
Hydrostar 200 (3 phase)	340	286	2	1.41	2.5	3	770	90	65mm ports x / 50mm unions
Hydrostar 250 (3 phase)	475	438	2.5	1.92	3.8	3	770	90	65mm ports x / 50mm unions
Hydrostar 300 (3 phase)	524	488	3	2.25	4.1	3	792	90	80mm ports x / 80mm unions

Phase	Volts	Cycle	RPM
1	220- 240	50	2860
3	380- 420	50	2860

Dimension

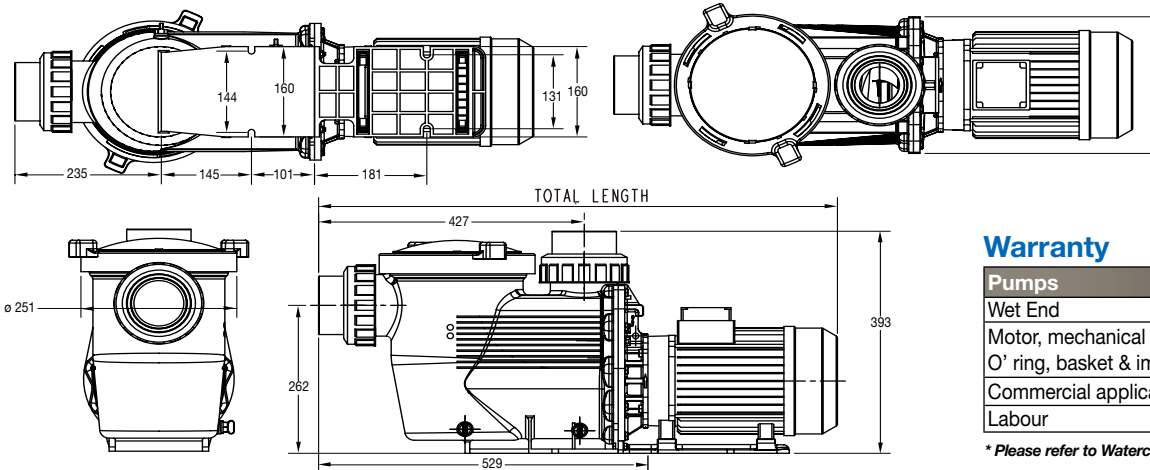

Warranty

Pumps	3 years (conditional) *
Wet End	3 years
Motor, mechanical seal, O' ring, basket & impeller	2 years
Commercial applications	1 year
Labour	1 year

* Please refer to Waterco's warranty terms and conditions

Waterco Limited

Waterco is an Australian public listed company involved in the manufacture and distribution of:

- Pool and spa equipment
- Pool and spa chemicals
- Domestic water filter, softeners and purifiers
- Commercial water treatment equipment



Waterco exports to over 40 countries via branches operating in Australia, New Zealand, Malaysia, China, the United Kingdom, United States of America, Canada and Indonesia as well as through international distributors.



OFFICES - AUSTRALIA

NSW - Sydney (Head Office)
Tel: +61 2 9898 8600

QLD - Brisbane
Tel: +61 7 3299 9900

VIC/TAS - Melbourne
Tel: +61 3 9764 1211

WA - Perth
Tel: +61 8 9273 1900

SA/NT - Adelaide
Tel: +61 8 8244 6000

ACT Distribution
Tel: +61 2 6280 6476

OFFICES - OVERSEAS

Waterco (Europe) Limited
Sittingbourne, Kent, UK
Tel: +44 (0) 1795 521 733

Waterco (USA) Inc
Augusta, Georgia, USA
Tel: +1 706 793 7291

Waterco Canada
St Hyacinthe, Quebec, Canada
Tel: +1 450 796 1421

Waterco (NZ) Limited
Auckland, New Zealand
Tel: +64 9 525 7570

Waterco (C) Limited
Guangzhou, China
Tel: +86 20 3222 2180

Waterco (Far East) Sdn Bhd
Selangor, Malaysia
Tel: +60 3 6145 6000

PT Waterco Indonesia
Jakarta, Indonesia
Tel: +62 21 4585 1481

Waterco Singapore Intl Pte Ltd
Marine Parade Centre,
Singapore
Tel: +65 6344 2378

DISTRIBUTED BY:

WATERCO
Water, the liquid of life

